

The Tiny CMOS Keyers

Kit Building and Operations Manual

Version 1.6

Congratulations on your purchase of the Tiny CMOS Keyer kit. Depending on which TiCK chip you have purchased, the features include lmbic modes A and B, adjustable speed control, tune function, paddle select, sidetone on/off, straight key mode, a 25 character message memory, and beacon mode. All TiCKs utilizes the latest in RISC-based microcontroller technology. This kit includes all board mounted parts; the user simply adds a power source and enclosure. Although we believe this kit to be easy to build, we recommend following the steps as listed below, in order to insure a working unit in the shortest period of time. Whichever

TiCK kit you have purchased, the construction procedure is the same.

Building the TiCK Kit

The first step is to inventory all the parts contained in the kit against Table 1. Be sure to check each component, and it will be helpful to tape each component to a piece of paper along with it's designation and value. Be extra careful with U1, the PIC microcontroller, as it is susceptible to static damage if mishandled. Be sure to ground yourself before handling U1 by touching a metal object which you know is grounded.

Table 1

DESIGNATION	TYPE	VALUE	MARKED AS:
C1, C2	Tantalum capacitor	1 uF	1.0
C3	capacitor - axial	.001 uF	102
C4, C5	capacitor - axial	.1uF	104
J1	stereo paddle jack		
J3	mono keyline jack		
R1	resistor - 1/4w	4.7K	yellow-violet-red
R2	resistor - 1/4w	27K	red-violet-orange
R3	resistor - 1/4w	1 Meg ohms	brown-black-green
P1	piezo audio transducer		
Q1	transistor		PN2222
S1	momentary switch		
U1	PIC microcontroller		PIC12C508/509
U2	5v voltage regulator	5v +	78L05
8 PIN SOCKET			
PC BOARD			TICK-1

Now that you have verified the parts, you can prepare to solder the parts on the board. You'll need a small-to-medium soldering iron, something in the 15-40 watt range. Use rosin core solder; a 60/40 mix of lead/tin is recommended. Radio Shack stores carry all the soldering supplies you would need to build this kit. Before starting the actual soldering, take a few minutes to look at these assembly instructions.

(1). Install the 8 pin socket which U1 will use. Notice that one end of the socket has a concave tab, which denotes the pin 1 end. Make sure the tab on the socket matches the silk screen overlay on the circuit board. Solder the socket onto the board, being careful not to apply too much heat and melting the socket. Do not install U1 at this time... it will be installed last.

- (2). Install capacitor C3. Do not install the other capacitors, they will be dealt with later.
- (3). Install resistor R1. Do not install the other resistors, they will be dealt with later.
- (4). Install Q1, the keyline transistor.
- (5). Beginning with this instruction, there are parts which will be optional, depending on the application you intend for the TiCK. Take a few minutes to read and consider these instructions before continuing.
- (6). Voltage Source: Embedded or Stand alone application

12V: If you want to power the TiCK from a 12v DC supply, the parts necessary for 12v-to-5v regulation must be added; this is done with U2 (78L05 voltage regulator), C1, and C2. **NOTE:** C1 and C2 must be installed with respect to their polarity! The "+" lead is identified by a marking on the body of the cap, as well as the "+" lead is the longer of the two! The voltage input is at J2, with the POSITIVE pad located closer to the center of the board, and GROUND pad closer to the edge of the board. **MAKE SURE THAT YOU DO NOT USE THE J4 BATTERY INPUT IF YOU ARE USING THE REGULATED SUPPLY INPUT!**

REGULATED 3-5V source: If your rig already has an internal regulated source, or you want to run off of a battery source for a stand alone application, then you may want to take advantage of this. The input for this regulated voltage is J4. If you decide on this option to power the unit, you do not need the following components: C1, C2 and U2.

(7) Audio feedback/sidetone:

Piezo Method: We wanted to make the TiCK kit as simple as possible, so we decided to provide a method of audio feedback and/or sidetone that would not require a connection to the radio audio chain. The way this is done is by providing an output for an piezo transducer to connect to. The piezo transducer connects between the two pins of J6. Polarity is not necessary. You will have to place a jumper for R3, and C4 and **NOT POPULATE R2 or C5.** This can be done by using a two small pieces of resistor lead. Bend the leads in a "U" and solder in place of R3 and C4. This jumpers pin 3 of the TiCK to J6 pin 1. There should be continuity between pin 3 of the TiCK and pin 1 of J6. This method allows for the easiest implementation of embedding a keyer into your rig. The **ONLY** connection required between the keyer and the rig is then connecting the keyline of the keyer (J3) to the keyline of your rig. This could be as simple as connecting to the front (or rear) panel key input of the rig.

Internal Audio Chain Method: We also decided to make it possible to experiment with adding the TiCK to a radio and

integrating it in the audio chain. We have set up the typical arrangement required to integrate the keyer into many rigs. This involves removing the current sidetone circuitry that is generated by your rig, and inputting the sidetone and feedback from the keyer (pin 3 TiCK). We included the following components to reduce the output voltage and couple it to the rig's audio chain: R2, R3, C4, C5. For the Norcal-40A, we have been told that the value for R2 is 27K, and R3 is 1Meg, but we have not tried this implementation. We leave this up to the experimenter to determine values for the rig in question.

BUT REMEMBER, IF YOU DONT WANT TO MAKE THIS COMPLICATED, JUST USE THE PIEZO!

(8). Now that the components have been placed and soldered on the board, the final wiring can take place. First jacks to be wired are paddle input (J1) and keyline output (J3). Both these jacks look identical, except that the keyline jack (J3) has a small spring inside it.

(8a). J1 and Paddle Input wires: requires 3 wires of equal length. The exact length should be sufficient to connect from the board to your choice of location for J1. J1 is the stereo, paddle input jack.

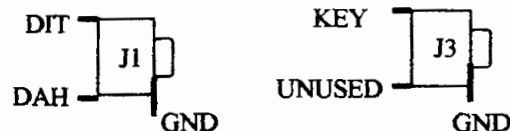

(8b). J3 and the keyline output wires: requires 2 wires of equal length. The exact length should be sufficient to connect from the board to your choice of location for J3.

(8c). J5 and S1: requires 2 wires of equal length. The exact length should be sufficient to connect from the board to your choice of location for S1.

(9). Install U1, the PIC microcontroller. Be careful to discharge yourself of any static electricity before handling the chip. Make sure the tab on the chip matches the location on the silk-screen, thus insuring correct orientation of the chip.

(10). At this point, hook up your paddles and supply power to the unit. When first powered up, the

TICK-1 will send "dit-dit", (while the TICK-2 will send dit-dit-dit", the TICK-2B will send "dah-dit-dit") through it sidetone output. If there is no audio output on the piezo, go back and check for the following:

Solder Bridges - Easily the most common mistake made. Check the bottom of the board for solder blobs, which serve to bridge two unconnected points. Use a magnifier and bright light if possible. Also check for unsoldered pins

and cold solder joints (these appear dull and somewhat rough).

Parts Placement - Go over the instructions and insure that each part is in it's correct position on the board. Something as simple as an incorrectly placed resistor may cause the unit to malfunction. Verify that the microcontroller is oriented correctly, with respect to the tab on it's end.

Silk Screen and Parts Placement Diagram

Below is a silk-screen of the Circuit Board, with additional details for construction.

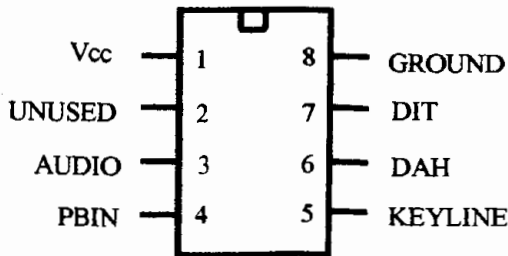
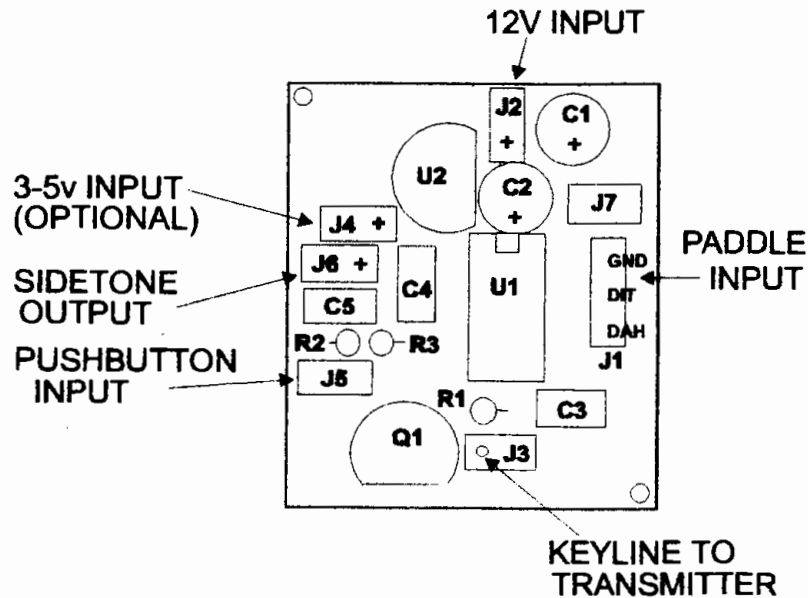

TICK-1/2/2B
PIC12C508/9
8 PIN DIP

TICK-1/2/2B PINOUTS	
PIN	DESCRIPTION
1	VCC - 3-5 VDC
2	UNUSED
3	AUDIO - 625Hz NOMINAL
4	PBIN - N.O. PUSHBUTTON INPUT
5	KEYLINE - LOGIC HIGH = KEYED LOGIC LOW = UNKEYED
6	DAH - INPUT
7	DIT - INPUT
8	GROUND

Appendix 1: Advanced TiCK Construction

Making the TiCK Consume Even Less!

The TiCK consumes very little power, but there is always room for improvement. These methods, although slightly more costly, and maybe the parts are not in your junk box, will reduce the current consumption even further of the TiCK.

Replacement of the 78L05 with a LP2950 as suggested in QRP Power¹. This will reduce the quiescent current consumption of the regulation circuit. This part is available from Digi Key for \$2.07. Part Number LP2950CZ-5.0-ND.

Also, using a bipolar transistor requires drive current. Even with a 4.7K base resistor, and operating at 5V this is about one milliamp, and considering that this will only be key down, this consumption is very minimal. But you can reduce it further by jumpering R1 and replacing Q1 with an N channel FET.

We have not experimented with different FETs, but there are many out here that will probably work fine. Replacing the PN2222 with a FET will reduce the operating current considerably, at the cost of finding something outside the realm of your local Radio Shack.

Reviews and Articles:

The TiCK keyers have been described and reviewed in many amateur radio journals, among them:

- Summer 97 issue of QRPp (TiCK-2 keyer)

- August 97 issue of CQ (TiCK-1 keyer)
- September 97 issue of CQ (TiCK-2 keyer & Surface Mount TiCKs)
- August 97 issue of Mobile Ham (Japanese Magazine, TiCK keyers)
- October 97 issue of World Radio (TiCK keyers)
- October 97 issue of QST (TiCK keyers)
- Fall 97 issue of QRPp (Surface Mount TiCK-2)
- January 98 issue of RadCom (TiCK-2 Keyer)

Questions:

If you should have any questions or comments regarding the TiCK, or if you would like to submit rig modifications for embedding the TiCK into your favorite rig, contact us via the following:

USMail: Embedded Research
 PO Box 92492
 Rochester, NY 14692

Internet: <http://www.frontiernet.net/~embres>

Email: embres@frontiernet.net

¹ QRP Power, compiled by Joel Kleinman (N1BKE) and Zack Lau (KH6CP/1), American Radio Relay League (ARRL), Newington CT, 1996. In the article, *Revisiting the 40-40*, Mitchell Lee (KB6FPW) and Dennis Monticelli (AE6C) describe alternatives to the L780X series of voltage regulators.

TiCK-1, 2 & 2B User Interfaces

The single button interface (SBI) makes the TiCKs simple to use. The general idea is that as long as the user holds the pushbutton down, the TiCK will allow sequential access to its various functions. After the code for the desired function is output through the sidetone, the user simply releases the button to access that particular function. Once the

function is completed, via paddle or possibly pushbutton input, the user is returned to operational or "keyer" mode.

User Interface Description (shaded areas denotes functions specific to the TiCK-2/2B chips, see legend below)

ACTION	TiCK RESPONSE	FUNCTION
Press pushbutton	"S" (dit-dit-dit)	SPEED Adjust: press dit to decrease, dah to increase speed
Hold Pushbutton Down	"M" (dah-dah)	MEMORY Playback : this will play the message from memory, using the keyline and sidetone (if enabled)
Hold Pushbutton Down	"T" (dah)	TUNE : to unkey rig, press either paddle or pushbutton
Hold Pushbutton Down	"A" (dit-dah)	ADMIN mode: this allows the user to access various setup parameters of the TiCK-2 & 2B chips.
Hold Pushbutton Down	"I" (dit-dit)	INPUT mode: allows the user to enter a message. User hits pushbutton when input is completed.
Hold Pushbutton Down	"P" (dit-dah-dah-dit)	PADDLE select: press paddle you want to designate as DIT paddle
Hold Pushbutton Down	"A" (dit-dah)	AUDIO select: press DIT to enable sidetone, DAH to disable. Default: enabled.
Hold Pushbutton Down	"SK" (dit-dit-dit, dah-dit-dah)	STRAIGHT KEY select: pressing either paddle toggles the TiCK to/from Straight Key/Keyer Mode. Default: Keyer Mode.
Hold Pushbutton Down	"M" (dah-dah)	MODE select: pressing the DIT paddle puts the TiCK into Iambic Mode A, DAH Iambic Mode B (default).
Hold Pushbutton Down	"B" (dah-dit-dit-dit)	BEACON select: pressing either paddle toggles the TiCK to/from Beacon/No-Beacon Mode. Default: No-Beacon Mode.
Hold Pushbutton Down	"K" (dah-dit-dah)	KEYER mode. If the user releases the pushbutton, keyer returns to normal operation.
Hold Pushbutton Down	"S" (dit-dit-dit)	Cycle repeats with SPEED adjust.

SHADING	DENOTES...
	TiCK-1/2/2B Feature
	TiCK-2 and TiCK-2B Feature
	TiCK-2B Feature Only

Notes:

Speed adjust: speed adjust continues as long as paddle is pressed; when paddle is released, speed is set at that point. Once the initial paddle is pressed, pressing the opposite paddle will cause the speed change to occur more quickly.

Message Playback: this allows the playback of a message previously input to memory. If either paddle is hit during the playback, the message playback will be terminated. **IMPORTANT:** On the TiCK-2B, a momentary button press will send the memory message. The TiCK-2B never sounds an "M" in code to the user.

Message Input: in message input mode, as soon as the first element is entered, the TiCK-2/2B begins storing dits, dahs, and space. This behavior will continue until either: the user hits the pushbutton, or memory is consumed.

Straight Key Mode: in order for straight key mode to function with a straight key, a mono (two wire) jack needs to be wired in parallel with the stereo (3 wire) paddle input jack. It is vital that one wire from the mono jack go to the ground jack on the paddle input; the other wire will work with either the dit or dah input.

Keyer Parameters: the TiCK uses its own internal Random Access Memory (RAM) to

store its operating parameters such as speed, dit/dah paddles, iambic mode, message memory, etc. When power to the TiCK is cycled, the values in RAM are lost and upon powerup the TiCK uses its default values.

Power-Up : upon power up, the TiCK-1 will signal it is ready by sending "dit-dit" (TiCK-2 "dit-dit-dit", TiCK-2B "dah-dit-dit-dit") through the audio line.

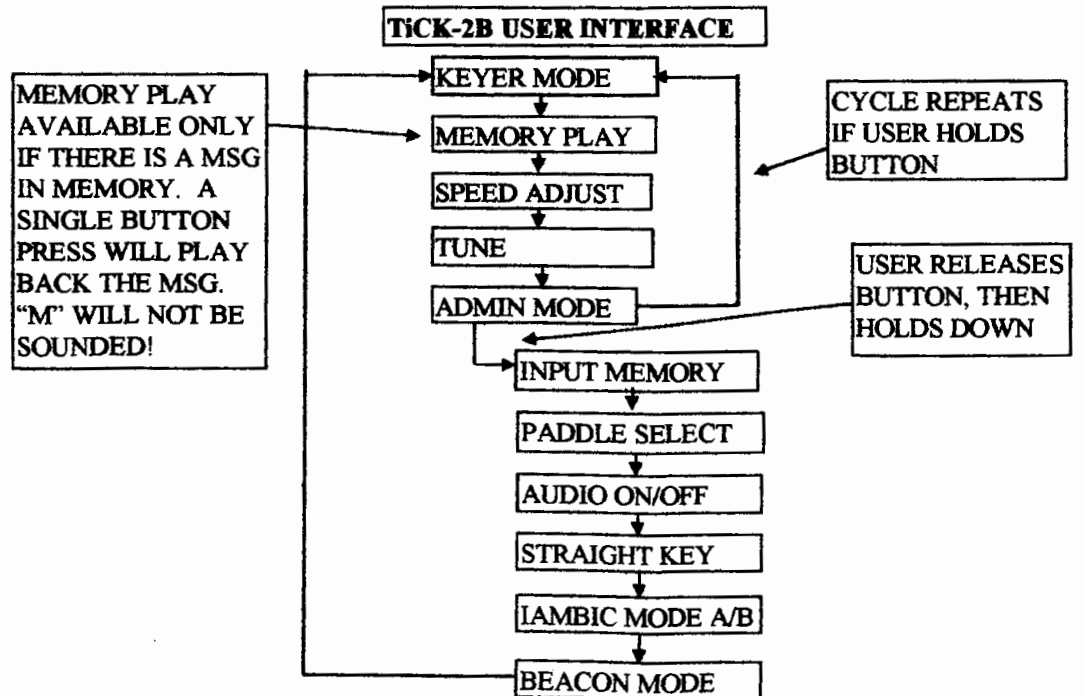
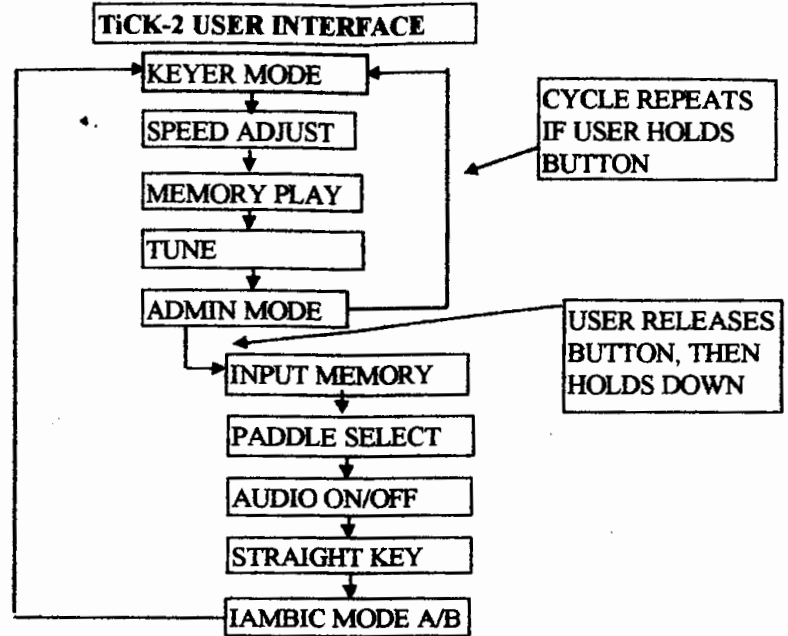
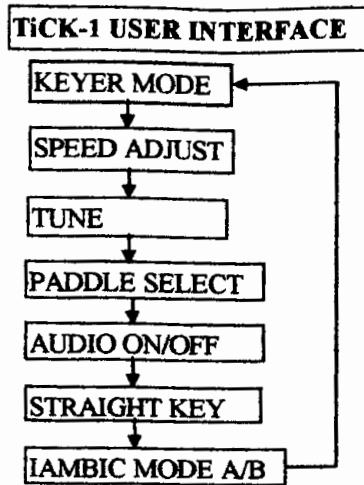

Copyright 1996 EMBEDDED RESEARCH

REVISION RECORD	
LTR	ECO NO: APPROVAL DATE:

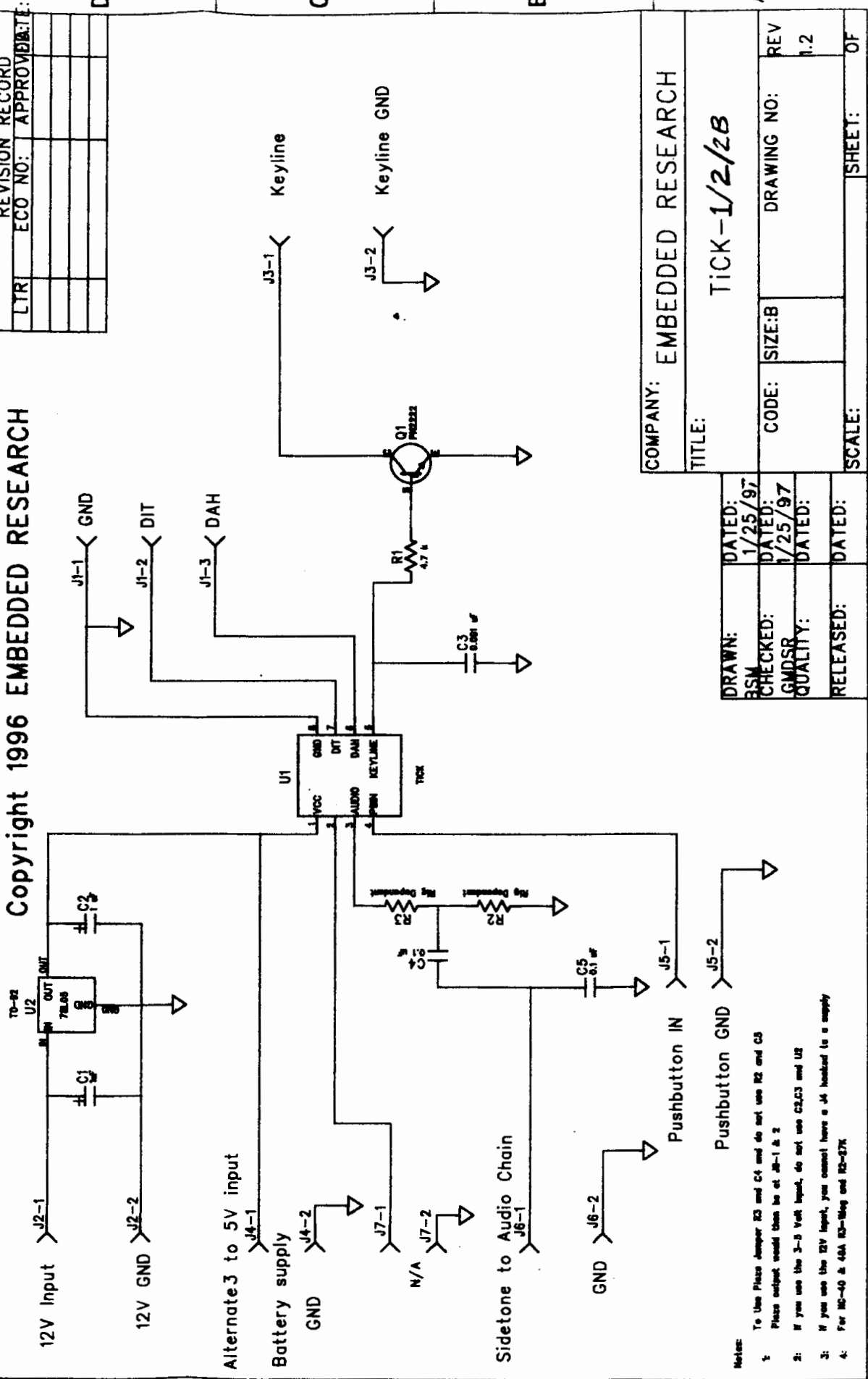

COMPANY: EMBEDDED RESEARCH

TITLE:

TICK-1/2/2B

DRAWN:	DATED:
BSM	1/25/97
CHECKED:	DATED:
GMSR	1/25/97
QUALITY:	DATED:
RELEASED:	DATED:

CODE: SIZE: B DRAWING NO: REV

1.2

SCALE: SHEET: OF

Notes:

- To Use Flux Ampers R2 and C4 and do not use R2 and C3
- Place output resistors in at J5-1 & 2
- If you use the 3-5 Volt input, do not use C2, C3 and U2
- If you use the 12V input, you cannot have a J4 hooked to a supply
- For MS-40 & 40A MS-Wag and MS-57K