

An Updated Universal QRP Transmitter

Looking for a project that will let you try some of your own “scratch built” ideas? Here is a starter low power transmitter circuit for that pursuit.

Wes Hayward, W7ZOI

A frequently duplicated project in the now out-of-print book *Solid State Design for the Radio Amateur*¹ was a universal low power (QRP) transmitter. This was a simple two-stage, crystal-controlled, single-band circuit with an output of about 1.5 W. The no frills design used manual transmit-receive (TR) switching. It operated on a single frequency with no provision for frequency shift. The simplicity prompted many builders to pick this QRP rig as a first solid state project.

The design simplicity compromised performance. A keyed crystal controlled oscillator often produces chirps, clicks or even delayed starting. The single π -section output network allowed more harmonic energy to reach the antenna than we, or the FCC, would really prefer. The relatively low output of 1.5 W, although fun and sporting for the seasoned QRP enthusiast, may seem inadequate to a first time builder.

A Three Stage Transmitter.

An updated design, Figure 1, develops an output of 4 W on any single band within the HF spectrum, if provided with 12 V dc. Q1 is a crystal controlled oscillator that functions with either fundamental or overtone mode crystals. It operates at relatively low power to minimize stress to some of the miniature crystals now available. The stage has a measured output at point X of +12 dBm (16 mW) on all bands. This is applied to drive control R17 to set final transmitter output.

An oscillator subtlety was observed during keying of the 80 meter version of the transmitter. The oscillator was slow to start, leading to an abbreviated or completely missing first dot. The problem was solved with a decrease in loading, realized with fewer turns on the T1 secondary.

A three stage design provides an easy way to obtain very clean keying. Shaped dc is applied to driver Q2 through a keying switch and integrator, Q4.² A secondary keying switch, Q5, applies dc to the oscil-



lator Q1. This is a time-sequence scheme in which the oscillator remains on for a short period (about 100 ms) after the key is released. The keyed waveform is shown in Figure 2.

The semiconductor basis for this transmitter is an inexpensive (less than a dollar!) transistor, the Panasonic 2SC5739. This part, with typical F_T of 180 MHz, is specified for switching applications, making it ideal as a class C amplifier. The transistor is conveniently housed in a plastic TO-220 package with no exposed metal. This allows it to be bolted to a heat sink with none of the insulating hardware required with many power transistors. I breadboarded a 2SC5739 power amplifier to confirm my expectations before continuing with the transmitter development. A 2 × 4 inch scrap of circuit board served as both a heat sink and as a ground plane for the circuitry.

I also used a 2SC5739 for the driver, Q2. This circuit is a feedback amplifier with RF feedback resistors that double to bias the transistor, a favorite topology of mine.³ Driver output up to 300 mW is available at point Y. Ferrite transformer T2 moves the 200 Ω output impedance seen looking into the Q2 collector to 50 Ω . The maximum output power of this stage can be changed with different R2 values. Higher stage current, obtained with lower R2 values, is needed on the higher bands. The 2SC5739 needs only to be bolted to the circuit board for heat sinking.

The Q3 power amplifier input is matched with transformer T3. The nominal 50 Ω of the driver is transformed to 12 Ω by T3.

My original design started with a simple L network output circuit at the Q3 collector followed by a third-order elliptic low-pass section to enhance harmonic suppression.⁴ C5 is a moderately high reactance capacitor at the collector to bypass VHF components. This L network presented a load resistance of 18 Ω to the Q3 collector, the value needed for the desired 4 W output. But this circuit displayed instabilities when either the drive power or the supply voltage was varied. The output amplifier sometimes even showed a divide-by-two characteristic. The original L network was modified with the original inductor replaced with an LC combination, C4 and L1. The new series element has the same reactance at the operating frequency as the original L network inductor. This narrow band modification provided stability on all bands. The components for the various bands are listed in Table 1.

The inductance values shown in Table 1 are those calculated for the networks, but the number of turns is slightly lower than the calculated value. After the inductors were wound, they were measured with a digital LC meter.⁵ Turns were compressed to obtain the desired L value. Eliminate this step if an instrument is not available.

The divide-by-two oscillations mentioned above could be observed with either an oscilloscope or a spectrum analyzer and

¹Notes appear on page 32.

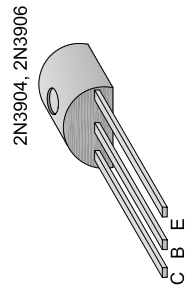
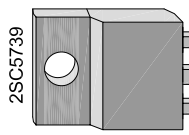
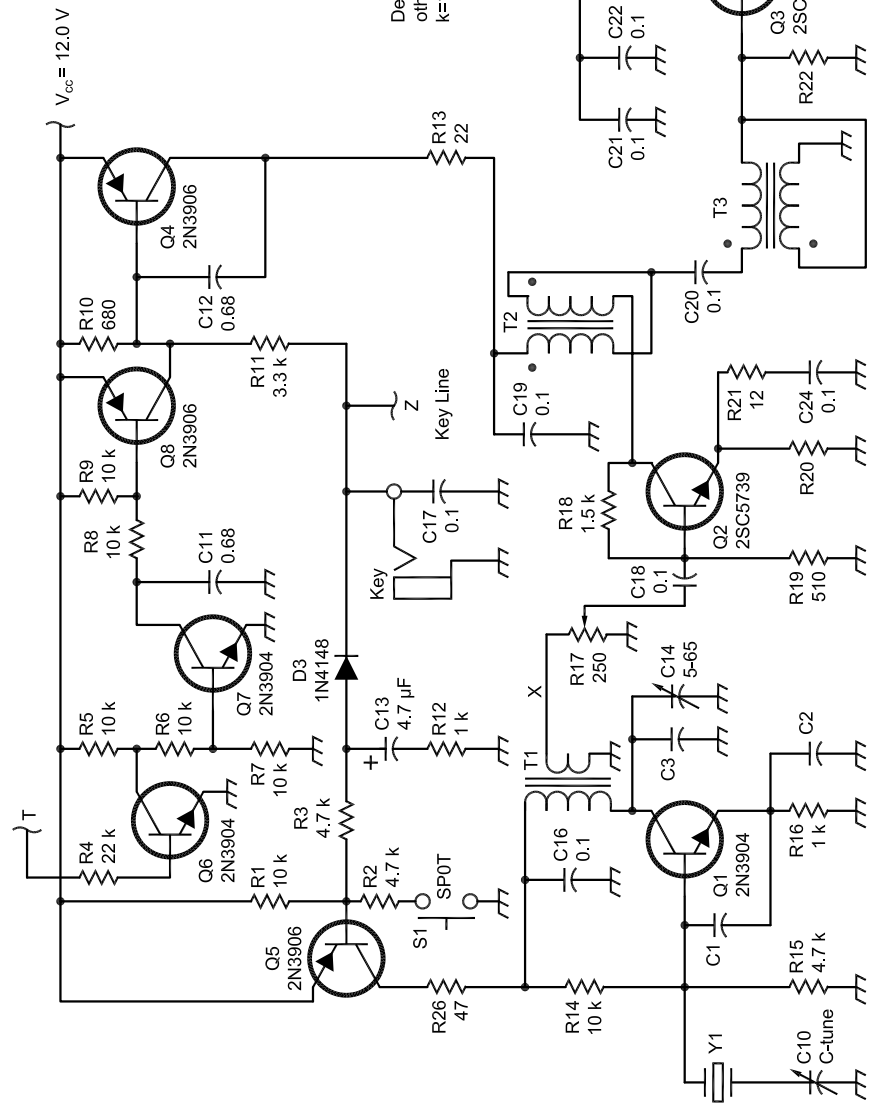

Decimal values of capacitance are in microfarads (μF); others are in picofarads (pF); Resistances are in ohms; k=1,000, M=1,000,000.

n.c. = Normally Closed
n.o. = Normally Open

9.4 V when P = 4 W

Figure 1 — Detailed schematic diagram and parts list for the RF portion of the Universal QRP transmitter. Resistors are 1/4 W, 5%. A kit of component parts is available from Kanga US. C10 is a VXO capacitor placed in series with the crystal to provide some frequency adjustment around the crystal frequency. Use what you have in your junk box, although smaller capacitance values provide a wider tuning range. We used a small 2 to 19 pF trimmer. TR switching is performed with a relay and additional circuitry shown in Figure 4.

- C1-C9 — See Table 1, all 50 V ceramic or mica.
- C10 — VXO control, see text.
- C11, 12 — 0.68 μF , 50 V metal film or Mylar.
- C13 — 4.7 μF , 25 V electrolytic.
- C14 — 5-65 pF, compression or plastic dielectric trimmer.
- C15-24 — 0.1 μF , 50 V ceramic.
- D1 — 1N976B, 43 V Zener diode.
- D2 — 1N4148, silicon general purpose diode.
- K1A — See Figure 4.
- L1, L2 — See Table 1.
- Q1, Q6, Q7 — 2N3904, NPN silicon small signal transistor.
- Q2, Q3 — 2SC5739 NPN silicon switching power transistor.
- Q4, Q5, Q8 — 2N3906, PNP silicon small signal transistor.
- R1, R5-R9, R14, R25 — 10 k Ω , carbon film resistor.
- R2, R3 — 4.7 k Ω , carbon film resistor.
- R4 — 22 k Ω , carbon film resistor.
- R10 — 680 Ω , carbon film resistor.
- R11 — 3.3 k Ω , carbon film resistor.
- R12 — 1 k Ω , carbon film resistor.
- R13 — 22 Ω , carbon film resistor.
- R15 — 4.7 k Ω , carbon film resistor.
- R16 — 1 k Ω , carbon film resistor.
- R17 — 250 Ω , potentiometer (a 500 Ω potentiometer in parallel with 270 Ω fixed resistor can be substituted).
- R18 — 1.5 k Ω , carbon film resistor.
- R19 — 510 Ω , carbon film resistor.
- R20, R22 — See Table 1, carbon film resistor.
- R21 — 12 Ω , carbon film resistor.
- R23, R24 — 2.2 k Ω , metal film resistor.
- RFC1 — 3.9 μH , 0.5 A molded RF choke.
- T1 — See Table 1
- T2 — on FT-37-43 or FB-43-2401 ferrite toroid core.
- T3 — 7 bifilar turns #28 enameled wire on FT-37-43 or FB-43-2401 ferrite toroid core.

Table 1
Band Specific Components of the Transmitter

Band MHz	T1 turns-turns wire, core	C1 pF	C2 pF	C3 pF	R20 Ω	R22 Ω	L1 nH, turns wire, core	L2 nH, turns wire, core	C4 pF	C5 pF	C6 pF	C7 pF	C8 pF	C9 pF
3.5	51t-3t #26, T68-2	200	270	100	33	18	3000, 26t #28, T37-2	1750, 20t #28, T37-2	1000	390	1000	1000	300	1000
7	32t-4t #28, T50-6	0	100	100	33	33	1750, 19t #26, T37-2	890, 14t #22, T37-2	470	200	560	470	150	470
10.1	32t-4t #28, T50-6	0	100	0	33	33	1213, 19t #28, T37-6	617, 13t #28, T37-6	330	120	390	330	100	330
14	32t-4t #28, T50-6	0	100	0	33	33	875, 16t #28, T37-6	445, 11t #28, T37-6	220	100	270	220	75	220
18.1	20t-3t #28, T37-6	0	33	0	33	33	680, 14t #28, T37-6	346, 9t #28, T37-6	180	75	220	180	56	180
21	20t-3t #28, T37-6	0	33	0	18	33	583, 12t #28, T37-6	297, 9t #28, T37-6	150	62	180	150	50	150
24.9	20t-3t #28, T37-6	0	33	0	18	33	490, 11t #28, T37-6	249, 8t #28, T37-6	133	56	150	133	43	133
28	20t-3t #28, T37-6	0	33	0	18	33	438, 10t #28, T37-6	223, 7t #28, T37-6	120	47	140	120	39	120

were one of the more interesting subtleties of this project. The oscilloscope waveform looked like amplitude modulation. In the more extreme cases, every other RF cycle had a different amplitude that showed up as a half frequency component in the spectrum analyzer. The amplitude modulation appeared as unwanted sidebands in the spectrum display for the “moderately robust” instabilities. (Never assume that designing even a casual QRP rig will offer no development excitement!)

I examined the output spectrum of this transmitter when V_{CC} was set to 12.0 V and the drive control was set for an output of 4 W. The relative harmonic outputs are presented in the second column (N=3) of Table 2 below with relative frequencies in the first. A 14 MHz version of the original two stage design (N=2) was also measured

at 12 V with output of 1.2 W with data in the third column of the table.

I breadboarded the oscillator and buffer section for all HF amateur bands from 3.5 to 28 MHz.⁶ The power amplifier circuit has been built at 3.5, 7, 14 and 21 MHz. The crystals, obtained from Kanga US, were fundamental mode units through 21 MHz, and third overtone above.⁷ The breadboard was built on two scraps of circuit board. Q1 and Q2 were on one with Q2 bolted to the board to serve as a heat sink. The second board had Q3 bolted to it, also serving as a heat sink.

After the breadboarding work was done,

I moved the circuits to an available 2 x 3 x 6 inch box, an LMB #138. A new circuit board scrap was used, but most of the circuitry was moved intact from the breadboard. I elected to build my version for 40 meters. A diode detector was added to aid tune-up. The final RF board is shown in Figure 3.

Transmit-Receive (TR) Switching

Numerous schemes, generally part of a transceiver, are popular for switching an antenna between transmitter and receiver functions. When carefully refined, full-break-in keying becomes possible, an

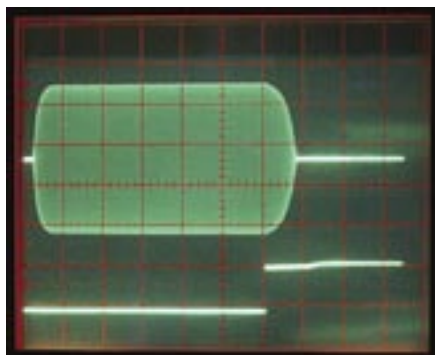

Figure 2 — Keyed waveform. The lower trace is the keyer input, which triggered the oscilloscope in this measurement. The horizontal time scale is 5 ms/div.

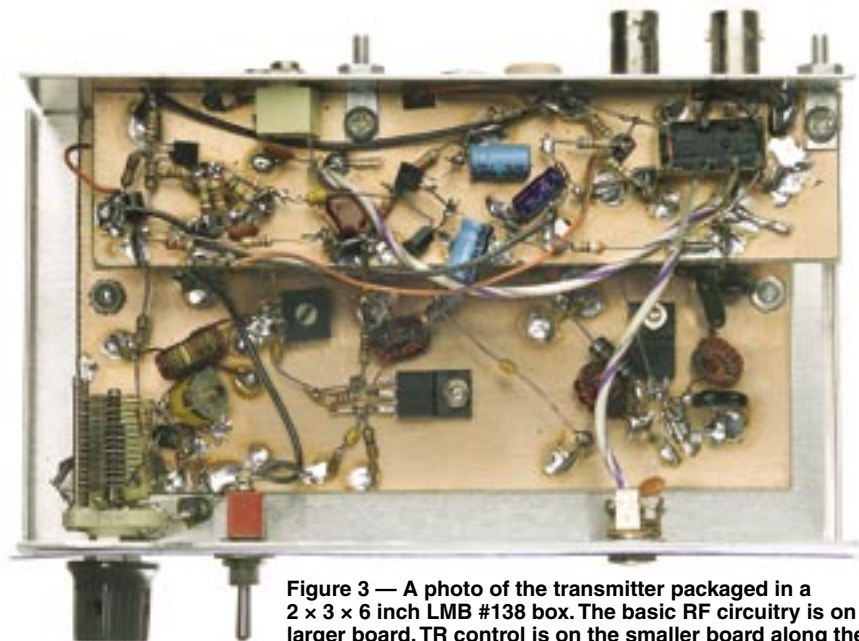

Figure 3 — A photo of the transmitter packaged in a 2 x 3 x 6 inch LMB #138 box. The basic RF circuitry is on the larger board. TR control is on the smaller board along the top.

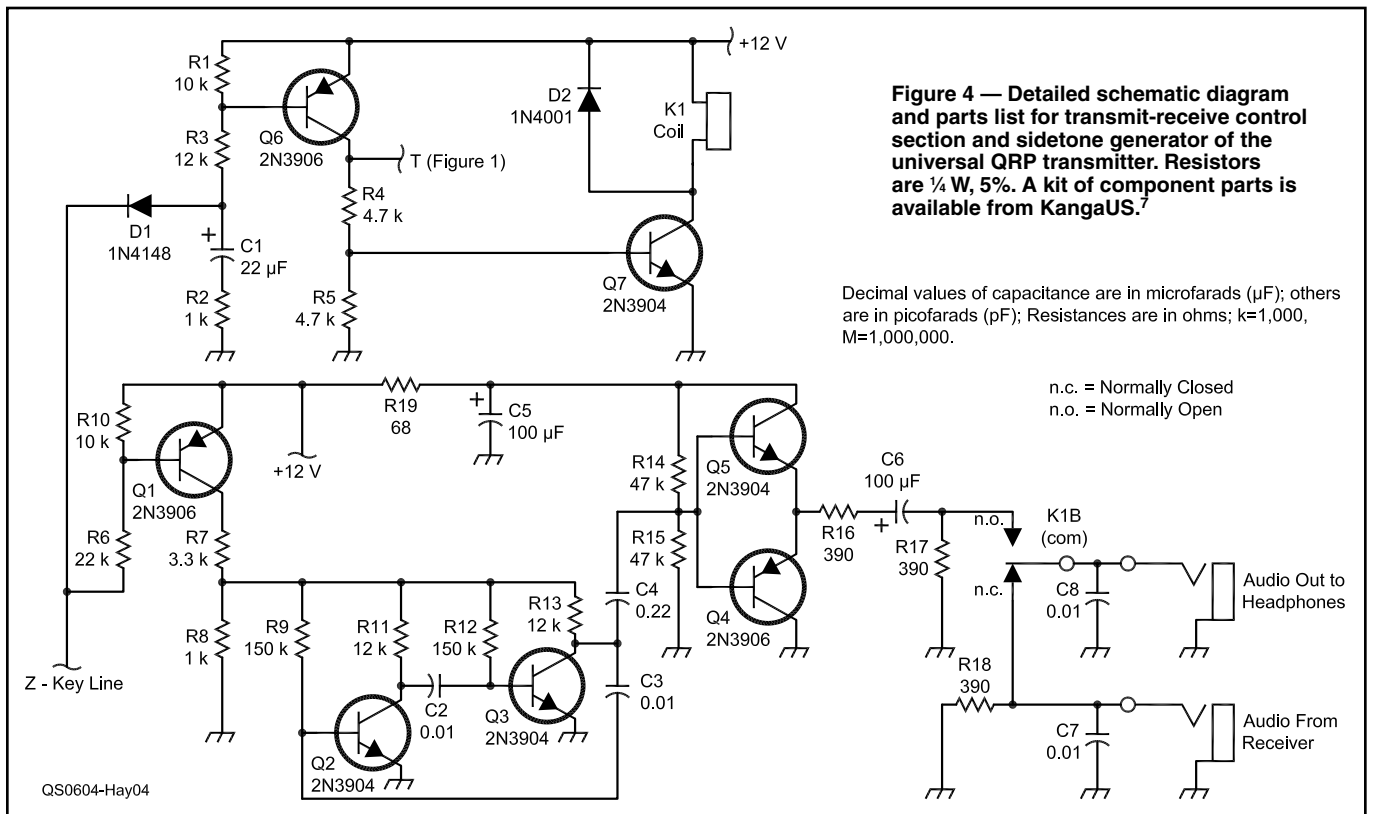

Figure 4 — Detailed schematic diagram and parts list for transmit-receive control section and sidetone generator of the universal QRP transmitter. Resistors are 1/4 W, 5%. A kit of component parts is available from KangaUS.⁷

Decimal values of capacitance are in microfarads (μF); others are in picofarads (pF); Resistances are in ohms; k=1,000, M=1,000,000.

n.c. = Normally Closed
n.o. = Normally Open

- C1 — 22 μF, 25 V electrolytic.
- C2, C3, C7, C8 — 0.01 μF, 50 V ceramic.
- C4 — 0.22 μF, 50 V ceramic.
- C5, C6 — 100 μF, 25 V electrolytic.
- D1 — 1N4148, silicon general purpose diode.
- D2 — 1N4001, silicon general purpose diode.

- K1 — DPDT 12 V coil relay. An NAIS DS2Y-S-DC12, 700 Ω, 4 ms relay was used in this example.
- Q1, Q4, Q6 — 2N3906, PNP silicon small signal transistor.
- Q2, Q3, Q5, Q7 — 2N3904, NPN silicon small signal transistor.
- R1, R10 — 10 kΩ, carbon film resistor.
- R2, R8 — 1 kΩ, carbon film resistor.

- R3 — 12 kΩ, carbon film resistor.
- R4, R5 — 4.7 kΩ, carbon film resistor.
- R6 — 22 kΩ, carbon film resistor.
- R7 — 3.3 kΩ, carbon film resistor.
- R9, R12 — 150 kΩ, carbon film resistor.
- R11, R13 — 12 kΩ, carbon film resistor.
- R14, R15 — 47 kΩ, carbon film resistor.
- R16-R18 — 390 Ω, carbon film resistor.

interesting option for transceivers. But these schemes tend to get in the way when one is developing both simple receivers and transmitters, perhaps as separate projects. A simple relay based TR scheme is then preferred and is presented here. In this system, the TR relay not only switches the antenna from the receiver to the transmitter, but disconnects the headphones from the receiver and attaches them to a sidetone oscillator that is keyed with the transmitter.

The circuitry that does most of the switching is shown in Figure 4. Line Z connects to the key. A key closure discharges capacitor C1. R2, the 1 kΩ resistor in series with C1, prevents a spark at the key. Of greater import, it also does not allow us to “ask” that the capacitor be discharged instantaneously, a common request in similar published circuits. Key closure causes Q6 to saturate, causing Q7 to also saturate, turning the relay on. The relay I picked for my example has a 700 Ω, 12 V coil with a measured 4 ms pull-in time.

Relay contacts B switch the audio line. R17 and 18 suppress clicks related to switching. I used low impedance headphones in

Table 2
Harmonic Spectral Output of the Original and Updated Universal QRP Transmitter

Fundamental	0 dBc (N=3)	0 dBc (N=2)
2 F	-80	-24
3 F	-58	-39
4 F	-71	-38
5 F	-71	-45
6 F	-81	-48
7 F	-80	-48

this system. A depressed key turns on PNP switch Q1, which then turns on the sidetone multivibrator, Q2 and Q3. The resulting audio is routed to switching amplifier Q4 and Q5. Although the common bases are biased to half of the supply voltage, emitter bias does not allow any static dc current to flow. The only current that flows is that related to the sidetone signal during key down intervals. Changing the value of R16 allows the audio volume to be adjusted, to compensate for the particular earphones used.

There is an additional interface between Figures 4 and 1. Recall that Q4 of Figure 1

keys buffer Q2 while Q5 provides a time sequence control to oscillator Q1. Additional circuitry uses Q6, Q7 and Q8, and related parts. Under static key up conditions, Q7 is saturated, which keeps C11 discharged. Saturated Q7 also keeps PNP transistor Q8 saturated. This closed switch is across the emitter-base junction of Q4. Hence, pressing the key will start relay timing and will allow the oscillator to come on, but will not allow immediate keying of Q2 through Q4. Key closure causes Q6 in Figure 4 to saturate causing point T to become positive. This saturates Q6 of Figure 1 which turns Q7 off, allowing C11 to charge. When C11 has charged high enough, Q8 is no longer saturated and Q4 can begin its integrator action to key Q2.

This hold-off addition has solved a problem of a loud click, yielding a transmitter that is a pleasure to use. There is still a flaw resulting in the initial CW character being shortened. The result is that an I sent at 40 WPM and faster comes out as an E. Further refinement of timing component values should resolve this.

The TR system circuitry for my transmit-

ter was built on a narrow scrap of circuit board that is then bolted to the transmitter rear panel.

What's Next?

This has been an interesting project from many viewpoints. The resulting transmitter, which is usually used with the S7C receiver from *Experimental Methods in RF Design*,⁸ is a lot of fun to use and surprisingly effective in spite of its crystal control. Primitive simplicity continues to have its place in Amateur Radio. Also, the development was more exciting than I would have guessed from the onset. The observed instabilities were interesting, as were the subtleties of the control system. Perhaps we should not approach simple CW systems with a completely casual attitude, for they continue to offer education and enlightenment.

There are clearly numerous refinements available for this transmitter. The addition of an adjustable reactance in series with the crystal will allow its frequency to move more. I used just a small variable capacitor. Two or more similar crystals in parallel form a "super VXO" topology for even greater

tuning range. Higher power supply voltage will produce greater output power. I saw over 10 W on the test bench. The transmitter could certainly be moved down to 160 meters for the top band DXer looking for QRP sport. It is not certain that the 2SC5739 will allow operation as high the 6 meter band. The transmitter could easily be converted to a modest power direct conversion transceiver using, for example, the Micromountaineer scheme offered in *QST*.⁹

There is no circuit board offered for this circuit. There are already numerous kits on the market. On the other hand, there are many seasoned experimenters interested in building a "from scratch" project and this is aimed at them. A "kit" consisting of a sack of parts for the transmitter is available from Kanga US.¹⁰

Many thanks to Bill Kelsey, N8ET, who verified the design and documentation by successfully building a 20 meter version of this transmitter.

Notes

¹W. Hayward, W7ZOI, and D. DeMaw, W1FB (SK), *Solid State Design for the Radio Amateur*, ARRL, 1977, pp 26-27.

²W. Hayward, W7ZOI, R. Campbell, KK7B, and B.

Larkin, W7PUA, *Experimental Methods in RF Design*, ARRL, 2003, p 6.63. Available from your ARRL dealer or the ARRL Bookstore, ARRL order no. 8799. Telephone 860-594-0355, or toll-free in the US 888-277-5289; www.arrl.org/shop/; pubsales@arrl.org.

³See Note 2, pp 2.24-2.28, for information on feedback amplifiers.

⁴See Note 3, p 3.6, for low pass filter designs, 3.29 for matching network designs.

⁵See www.aade.com for details. A homebrew alternative is offered in Note 2, Chapter 7. Also see Carver, "The LC Tester," *Communications Quarterly*, Winter 1993, pp 19-27.

⁶See Note 2, p 1.2, and Hayward and Hayward, "The Ugly Weekender," *QST*, Aug 1981, p 18.

⁷See www.kangaus.com.

⁸See Note 2, p 12.16.

⁹Hayward and White, "The Micromountaineer Revisited," *QST*, Jul 2000, pp 28-33.

¹⁰See Note 7.

Wes Hayward has been licensed as W7ZOI since high school in 1955. His career in electron-device physics and circuit design took him to Varian Associates, Boeing, Tektronix, and TriQuint Semiconductor. He is now semi-retired and devotes his time to writing, consulting and some circuit research with a smattering of back-packing. His latest writing effort is the ARRL book (with KK7B and W7PUA), Experimental Methods in RF Design. You can reach Wes at 7700 SW Danielle, Beaverton, OR 97008, or at w7zoi@arrl.net.

